



## Completion of the Custom Wiring Harness Worksheet

The second page of this document is the wire harness worksheet that must be completed and FAXed back to PS Engineering, Inc. Upon the receipt of the worksheet, PS Engineering, Inc. will debit the credit card for the entire amount of the harness plus any other additional hardware or shipping charges that are indicated on the wire harness worksheet.

Wire Harnesses are not **cancelable** or **returnable**.

Allow five-business days from our receipt of your harness worksheet to the time the harness is shipped.

The best technique to measure the needed cable lengths is to take a piece of string, and run it from the desired unit location to the desired jack location, next to, or through the aircraft structure along the planned cable route. Then measure that string to determine the wire run. Repeat for each individual run (pilot jacks, passenger jacks, music jacks etc.).

Enter the length in the "Length (feet)" column. If the length is longer than the basic length included in the base price, there will be an extra per-foot cost. (No, you won't get credit if the length is LESS than the base cost). If any of the column boxes are empty, then PS Engineering will assume that wire connection is not required or needed.

The base price is the cost of building the basic harness with minimum required connections, while the per-foot cost is the cost of the wire to the termination. For instance, the pilot headphone will cost \$27.50 for a 10-foot cable run ( $\$2.75 \times 10'$ ). If your installation does *not* have certain radios or connections, you will not be charged a foot price. Total the far right column to determine the harness price.

Specify the receivers to be included, such as ADF, DME, or Auxiliary (RX). Specify number of unswitched audio sources, up to 4. Multiply \$5.00 by number of receivers, NOT length, because length is same as the as navcoms. Specify which inputs to use (see manual §2.4.10) for a description of the differences.

The "Swap" (S) mode allows the pilot to switch from COM 1 to COM 2 and back using a remote momentary switch (switch not included). The internal recording system can be played back from the front panel, or using a remote momentary switch (PB) (switch not included).

Resist the temptation to use the lengths listed on the worksheet. These are listed not because they are any type of standard lengths, but rather, provides PS Engineering, Inc a basis for the cost of the harness.

Ordering a harness with excessive wire lengths will increase the likelihood of Radio Frequency Interference (RFI). The only alternative to a too long a wire run is to cut it to length. However, this eliminates the work that had already been done in prepping the wires and will require special tools to re-prepare the wires for termination to the mic and headphone jacks.

Passenger head<sup>phone</sup> jacks are "daisy-chained." That means that a single cable will connect the unit to the first set of passenger jacks (L1). From there, another wire will go the next set of passenger jacks (HC), and then to the last set of jacks (H4). All microphone connections are separate cables from the unit to the mic jacks (M2, 3 etc.).

We typically do not install intercom headphone jacks on the harness unless specifically requested. It is usually easier to feed the wires through the airplane without the jacks attached to the harness. However, if you elect to have us install jacks to your harness we will be glad to do so. The cost is \$8.75 for each set of headphone and microphone jacks.

Power and ground wires will be the length you specify. The lengths should include the distance from the circuit breaker on the avionics bus (power) and the ground location (ground) to the PMA9000EX. **Specify the voltage of the aircraft dimmer (14 or 28V).**

We provide a specified length of wires for interface to the aircraft radio. These wires are stripped and timed, and ready to have the corresponding radio connector pins installed. Consult the radio manufacturer's installation manual for connection information, and contact your PS Engineering dealer for help if needed.

A hardcopy order sheet is required, no phone orders accepted. Scanned sheets can be emailed to [harnesses@ps-engineering.com](mailto:harnesses@ps-engineering.com).

## PMA9000EX HARNESS ORDER SHEET

**HARNESS IS NON CANCELLABLE AND NON RETURNABLE**

NAME: \_\_\_\_\_ DATE: \_\_\_\_\_  
 ADDRESS: \_\_\_\_\_ PHONE: \_\_\_\_\_  
 \_\_\_\_\_ Ship Method: \_\_\_\_\_  
 City: \_\_\_\_\_ State: \_\_\_\_\_  
 Zip/Post Code: \_\_\_\_\_  
 Visa/MC#: \_\_\_\_\_ Expiration: \_\_\_\_\_  
 Aircraft Make & Model: \_\_\_\_\_ 14V or 28V? (check one)

Designation	Location	Length (feet)	Price per foot	Total = Base + (cost per foot x length)	
<b>Base Cost:</b>				<b>\$268.88</b>	
Intercom	LP	PMA9000EX to Pilot Jacks		\$ 2.75	
	LC	PMA9000EX to Copilot Jacks		\$ 2.75	
	L1 (if more than 2-place)	PMA9000EX to Passenger 1 Jacks		\$ 2.75	
	HC (if 4-place)	Passenger 1 Phones to Passenger 2 Phones		\$ 1.15	
	H3 (if 6-place)	Passenger 1 Phones to Passenger 3 Phones		\$ 1.15	
	H4 (if 6-place)	Passenger 2 Phones to Passenger 4 Phones		\$ 1.15	
	M2 (4-place)	PMA9000EX to Passenger 2 Mic		\$ 1.15	
	M3 (6-place)	PMA9000EX to Passenger 3 Mic		\$ 1.15	
	M4 (6-place)	PMA9000EX to Passenger 4 Mic		\$ 1.15	
	E1	PMA9000EX to Music Jack		\$ 1.15	
E2	PMA9000EX to Passenger Music Input		\$ 1.50		
Audio Panel	NC1	PMA9000EX to Nav/Com 1			
		Com 1 Phones & Microphone		\$ 2.75	
		Nav 1 (if present)		\$ 1.15	
	NC2	PMA9000EX to Nav/Com 2			
		Com 2 Phones & Microphone		\$ 2.75	
		Nav 2 (if present)		\$ 1.15	
	RX	PMA9000EX to ADF, DME, AUX			
	US	PMA9000EX to unswitched audio			
	Specify number of unswitched audio sources, up to 4. Multiply \$5.00 by number of receivers, NOT length, if length is same as the as navcoms. Specify which inputs to use (circle) #1, #2, #3, #4 (see manual §2.4.10)			\$1.00 per foot, per receiver	
	Multiply by number of receivers (ADF, DME, etc)			\$ 1.15	
PG	Power and Ground		\$ 0.20		
SP	Cockpit Speaker		\$ 1.15		
DIM	PMA9000EX to radio dimmer (Specify 14 or 28V)		\$ 0.20		
PB	Remote switch for Internal Recorder Playback		\$ 0.20		
S	Optional Swap switch (switch not included)		\$ 0.20		
	Headset and Mic jacks added to the harness		\$8.75 x # of sets		
			<b>Total:</b>		

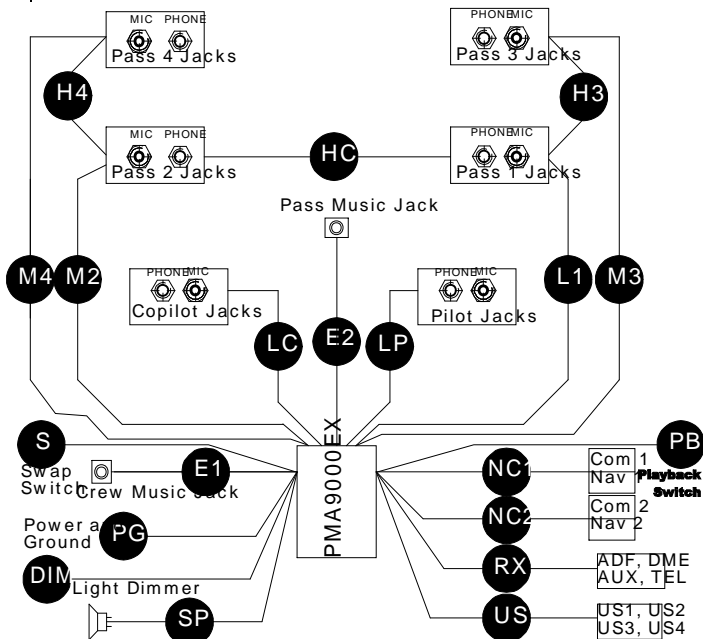

**Notes:**  
 Each harness is professionally manufactured using Mil-Spec, Tefzel® shielded cable, and is clearly marked for easy identification using heat shrink labeling. Turn-around time is 5-business days from receipt of completed worksheet, or shipping is free.  
**Jacks are not included.** Please add \$8.75 per set of mic and headphone jacks.  
 Special Instructions: \_\_\_\_\_  
 \_\_\_\_\_  
 \_\_\_\_\_  
 \_\_\_\_\_  
 \_\_\_\_\_